

Ductwork Components

Channel Profile System

Custom Made Profiles Details & Specifications

- Channel is available in both plain and with pre-formed close pitch slots.
- Custom made profiles to suit specific customer requirements available. Bespoke lengths to order.
- Versatile profile satisfies the requirements of multiple applications.
- Profiles also available in different materials, complies to BS 6946:1988.
- Load capacity can be advised for further spans.
- Standard profile geometry allows the use of industry standard brackets and fixings.
- No further treatment required as the channel is manufactured from pre-galvanised M.S. Z275 Coating.
- Product tested according to BS EN 5950-5:1998 & BS EN 1993-1-3:2006. Complies with B&ES DW144.

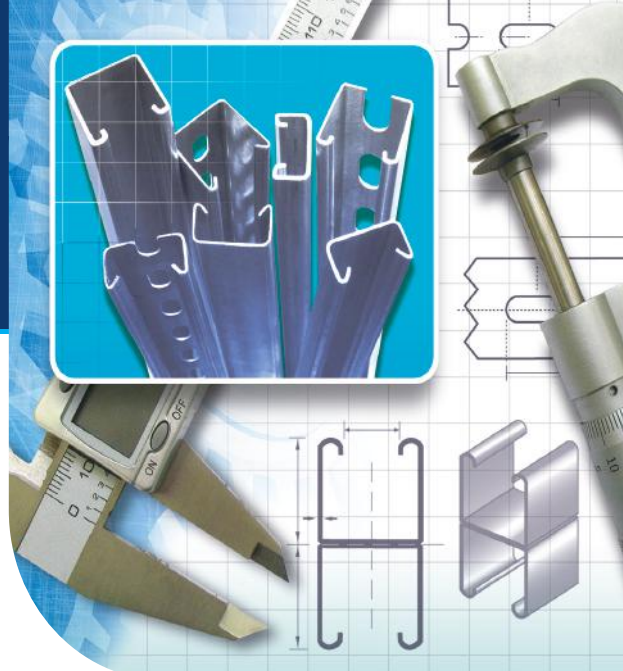

Doby Verrolec Channel Profiles

The channel profiles are designed to provide an effective yet economical solution to the support of a wide variety of items throughout the various industry sectors.

Material Specification

Profile	Gauge (mm)	Weight /m (Kg)	Finish
DS253	1.5	1.14	Plain
DS254	1.5	1.63	Plain
DS255	2.5	1.79	Plain
DS256	2.5	2.60	Plain
DS456	2.5	5.20	Plain
DS257	1.5	1.08	Slotted
DS258	1.5	1.56	Slotted
DS259	2.5	1.69	Slotted
DS260	2.5	2.49	Slotted

British Standard steel grade and coating specification:

BS EN 10346:2015 DX51D +Z275 MAC

Channel Profiles are also available in Stainless & Aluminium to order. Other special gauges can be produced to customer requirements. Channel fittings - refer to Sales Office.

Production Lengths

Profile Ref:	Length
DS253	Made to order
DS254	Made to order
DS255	Made to order
DS256	Made to order
DS257	3m lengths
DS258	3m lengths
DS259	3m lengths
DS260	3 & 6m lengths
DS456	3 & 6m lengths

Slot Details

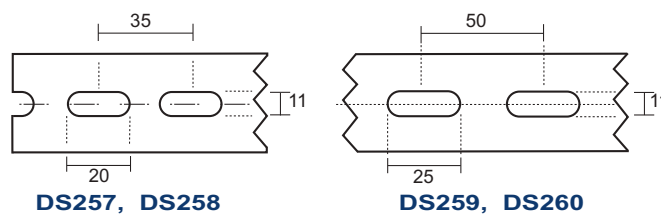

DS257, DS258

DS259, DS260

Support Section Requirements

Suggested support section requirements based on B&ES specification DW144 table 15, Figure 68.

1 Maximum Duct Size Longest Side Horizontal	2 DS Support Section ref.	3 Drop Rods Dia.	4 Maximum Spacing of Supports mm	5 Approx. Weight of Duct c/w Flange kg.
400	DS253 / DS257	M6	3000	33
600	DS253 / DS257	M8	3000	51
1000	DS253 / DS257	M8	3000	92
1500	DS254 / DS258	M10	2500	150
2000	DS256 / DS260	M10	2500	200

Notes

1. Details are based on horizontally supported ducting.
2. Column 5 gives approximate weight of maximum size of duct in that range including flanges.
3. Maximum drop rod centres should not exceed dimensions in column 1 by more than 100mm.

Packing Details

Length	Bundle Size
3000mm	150 metres
6000mm	300 metres



Loading Arrangements

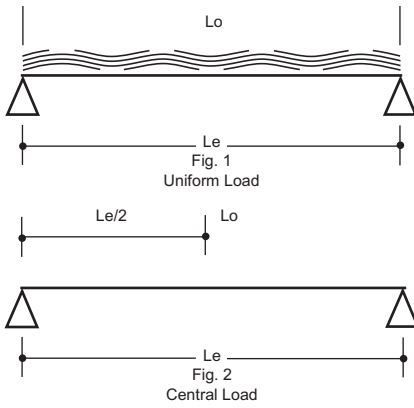

Selection Procedure

1. Calculate span 'Le' between mounting points (M).
2. Calculate load 'Lo' to be carried on channel (Kg).
3. If the most appropriate loading is Fig. 1 from the tables read off the span of the channel which is capable of carrying the closest greater load than the newly calculated load (Lo).
4. If the most appropriate loading is Fig. 2, multiply load from tables by 0.5 and deflection by 0.85.

Notes

Data is based upon uniformly distributed loads. Safety factor 1.6 for beam loading and 1.4 for column loading (at centroid of section).

Stress 187N/mm².

(1) - Max safe working load recommended when deflection is not critical, especially on larger spans.

(2) - Deflection 1/200th of span recommended when deflection should be limited.

(3) - Deflection 1/360th of span recommended when deflection needs to be imperceptible.

(4) - Column load when channel is used as a column rather than beam.

Uniform Load Capacity

Profile			Le (m)	Safe working loads in kg Uniform		Def. Limit 1/200 of Span - kg	Def. Limit 1/360 of Span - kg	Safe column loads at centroid - kg
Code	Ixx (mm ⁴)	Area (mm ²)		Load (kg)	Def. (mm)			
DS253	7908	158	0.50	201	2.6	195	108	2039
			0.75	134	5.5	91	51	1162
			1.00	100	9.6	52	29	681
			1.25	80	15.1	33	18	443
			1.50	67	22.4	22	12	310
			2.00	50	41.1	12	7	Le/rxx > 180
			2.50	40	68.2	7	4	
3.00	33	105.6	5	3				
DS254	49460	225	0.50	656	2.1	-	427	3453
			0.75	437	3.1	-	295	3311
			1.00	328	5.0	328	182	3001
			1.25	262	7.5	218	121	2400
			1.50	219	10.9	150	83	1797
			2.00	164	19.9	83	46	1060
			2.50	131	31.8	52	29	690
3.00	109	47.6	34	19	484			
DS255	11179	244	0.50	310	2.5	-	172	3034
			0.75	207	5.4	142	79	1657
			1.00	155	9.6	81	45	966
			1.25	124	14.9	52	29	627
			1.50	103	22.1	35	20	439
			2.00	77	40.2	19	11	Le/rxx > 180
			2.50	62	65.7	12	7	
3.00	52	98.4	8	4				
DS256	73857	349	0.50	979	1.5	-	893	5345
			0.75	653	2.8	-	478	5113
			1.00	490	4.8	-	286	4595
			1.25	392	7.2	342	190	3623
			1.50	326	10.5	232	129	2696
			2.00	245	18.8	131	73	1585
			2.50	196	29.9	82	45	1032
3.00	163	44.3	55	31	723			
DS257	6905	140	0.50	191	2.6	182	101	1800
			0.75	128	5.5	87	48	1017
			1.00	96	9.6	50	28	595
			1.25	77	15.1	32	18	387
			1.50	64	22.2	22	12	271
			2.00	48	40.9	12	6	Le/rxx > 180
			2.50	38	65.4	7	4	
3.00	32	102.3	5	3				
DS258	43858	208	0.50	608	2.3	-	370	3179
			0.75	405	3.0	-	277	3041
			1.00	304	4.8	-	175	2732
			1.25	243	7.4	208	116	2153
			1.50	203	10.2	146	81	1601
			2.00	152	18.7	81	45	941
			2.50	122	28.3	51	29	613
3.00	101	41.2	35	19	430			
DS259	9677	216	0.50	268	2.4	-	69	2660
			0.75	179	5.1	130	72	1438
			1.00	134	8.9	64	36	837
			1.25	107	13.9	47	26	543
			1.50	89	20.1	32	18	380
			2.00	67	36.1	18	10	Le/rxx > 180
			2.50	54	57.7	11	6	
3.00	45	85.8	7	4				
DS260	65126	321	0.50	946	1.7	-	793	4792
			0.75	631	2.9	-	456	4469
			1.00	473	4.8	-	273	3869
			1.25	378	7.4	320	178	3020
			1.50	315	10.6	224	124	2272
			2.00	236	18.8	126	70	1357
			2.50	189	30.0	79	44	890
3.00	158	44.4	53	30	Le/rxx > 180			
DS456	382398	698	0.50	2845	1.2	-	2107	10535
			0.75	1896	1.5	-	1214	10026
			1.00	1422	2.4	1364	758	9176
			1.25	1138	3.5	887	493	7783
			1.50	948	4.9	603	335	6168
			2.00	711	8.6	341	190	3810
			2.50	569	13.3	219	122	2522
3.00	474	19.2	148	82	Le/rxx > 180			

All dimensions in millimetres